



# Community Partners for Clean Streams



## SERIES #2: Maintaining Engineered Stormwater Controls



## **COMMUNITY PARTNERS FOR CLEAN STREAMS**

*NOTE: This handbook is one in a series of handbooks that describe specific practices businesses can use to protect water quality. A complete list of all handbooks and fact sheets available through the Community Partners for Clean Streams program is provided on the inside of the back cover. To obtain other handbooks in this series contact the Program Manager at the address or phone number provided below.*

### **Becoming a "Community Partner for Clean Streams"**

We hope you'll join with the Washtenaw County Drain Commissioner's office and other area businesses and institutions by participating in the Community Partner for Clean Streams program. Through this program, businesses help protect the Huron River and local streams.

To participate in the program, fill out the checklist in the back of this handbook. Send it to the address below and our staff will work with you to become a Community Partner for Clean Streams. In return for your effort, we'll publicly acknowledge your business through newspaper articles, displays and speaking engagements. We'll also encourage consumers to look for the Community Partners logo at your business when they select services.

### **Washtenaw County Award for "Environmental Excellence"**

By becoming a Community Partner, your business will have completed the water quality criteria for Washtenaw County's "Environmental Excellence" award. This annual award is presented to businesses in the County that proactively protect the environment. For more information about this award program, contact the Community Partners Program Manager:

**Community Partners for Clean Streams Program Manager  
Washtenaw County Drain Commissioner's Office  
110 N. Fourth Ave.  
Ann Arbor, MI 48107-8645**

**Phone: (313)994-8344 or 994-2525  
Fax: (313)994-2459**



# Catch Basin Care



## Why be concerned?

Catch basins are structures located where water enters a storm drain or where pipes intersect. Their main function is to collect runoff and convey it into the stormwater management system. Many are also designed to let sediment and other debris settle into a storage area at the bottom of the catch basin. This helps prevent debris from flowing into the drainage system.

It's important to maintain catch basins. In addition to preventing storm sewer blockages, proper maintenance prevents accumulated pollutants from being stirred up during a storm and washed through the system into rivers and streams.

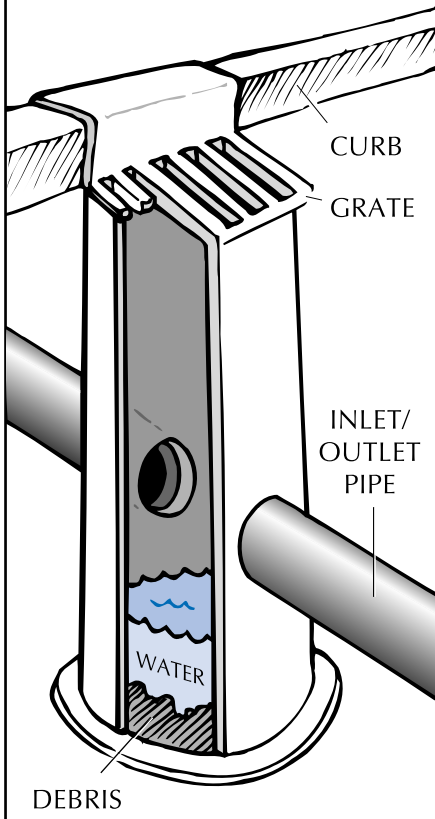

## Removing Debris from Storm Drain Grates

Storm drain grates can become clogged with litter or leaves, especially in the spring and fall. Regular inspection and removal of debris can help prevent pollution downstream, as well as blockages that can lead to localized flooding.

## The Importance of Regular Inspections

If you own or maintain a business site, check your catch basins at least twice a year to see if they need cleaning. If you wait any longer, debris may accumulate in the outlet pipe. This will make cleaning the catch basin much more time-consuming and expensive.

To find out how much material has accumulated in the storage area of your catch basin, insert a long, thin probe into the storm drain grate. Notice where your probe hits the debris and continue probing to the bottom to estimate how deep the accumulation is.

## Cleaning Your Catch Basins

Catch basins should be cleaned out before the storage area is half full. Once this level is reached, solids begin to be washed out of the basin. Cleaning should be done in the spring, after the first large snow melt, in the fall, after the trees have shed their leaves, and additionally if needed.

If the catch basin is shallow enough you may be able to clean it out yourself with a shovel and bucket. Be careful not to drop the basin's cover down the opening when you remove it — it can be extremely hard to retrieve. If you can't perform your own maintenance, professional services are available to do it for you. For assistance identifying suitable contractors, contact one of the agencies listed under "Getting Help."

## Disposing of Excavated Material

Solids removed from catch basins may be high in pollutants such as oil, metals, chemicals and nutrients. To determine how to properly dispose of these solids, contact the waste disposal facility where you expect them to be taken. Hiring a professional service to maintain your catch basins can help to ensure that solid wastes are handled properly.

## Stenciling Your Storm Drains

Stenciled messages that say *Dump No Waste, Drains to River* are a good reminder that nothing but water belongs down a storm drain. Community Partners for Clean Streams will loan stencils to businesses in the area.

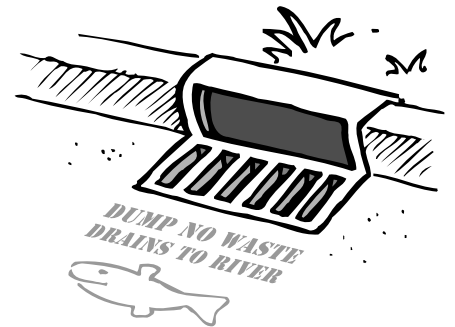

## GETTING HELP

Michigan Department of Environmental Quality ..... (800) 662-9278

Washtenaw County Drain Commissioner's Office ..... (313) 994-2525

Community Partners for Clean Streams ..... (313) 994-8344

### Utilities Departments:

City of Ann Arbor ..... (313) 994-2466

City of Ypsilanti ..... (313) 482-1025





# Oil/Water Separators

## Why be concerned?

If it's allowed to enter a river or stream, one quart of oil can contaminate up to two million gallons of water! In addition, the Drain Commissioner's office has managed cleanups costing over \$200,000 in response to illegal petroleum releases to the Huron River system. If the source of an oil spill can be tracked, the responsible business is liable for these costs.

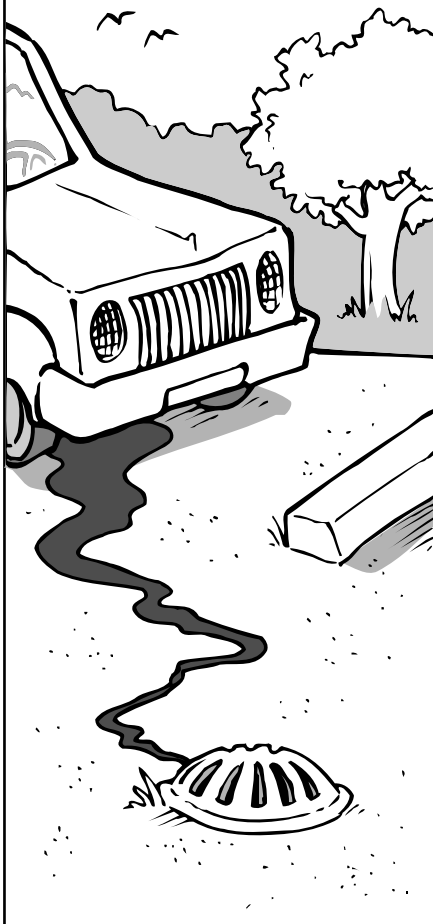

## The First Step: Eliminate Oil at its Source

*Oil/water separators aren't designed to receive large amounts of oil and don't remove all oil from stormwater before it's discharged. Therefore, it's important to eliminate oily runoff at its source. (For example, promptly fix oil leaks on company vehicles.)*

## What *is* an Oil/Water Separator?

Oil/water separators are designed to remove sediment, oil and grease from stormwater runoff. They're used in areas with heavy traffic or high potential for petroleum spills, such as parking lots, gas stations, and loading areas.

Oil/water separators are usually located close to the pollutant's source, so they can remove contaminants before runoff enters the storm water system. Two of the more commonly used designs are:

- Simple oil/water separators, which are structures with a T- or elbow-shaped pipe that traps floating pollutants.
- American Petroleum Institute (API) separators, which consist of long vaults with baffles. The baffles slow down the water, increasing the opportunity for oil to float to the surface and for heavy pollutants to settle out.

HOW TO TURN YOUR  
CATCH BASIN INTO A SIMPLE  
OIL/WATER SEPARATOR:

## Installing an Oil/Water Separator

Oil/water separators are an effective pollution control device for:

- gas stations
- car repair shops
- fleet vehicle yards
- heavy equipment storage and maintenance facilities

If you store or transfer liquid materials, it's a good idea to have an oil/water separator. An existing catch basin can be turned into a simple oil/water separator simply by adding a T- or elbow-shaped section of pipe. There needs to be at least one foot between the bottom of the pipe and the bottom of the catch basin so that there's space for sediment to accumulate. If you use an elbow-section, be sure that it's removable so the catch basin can be cleaned as needed.

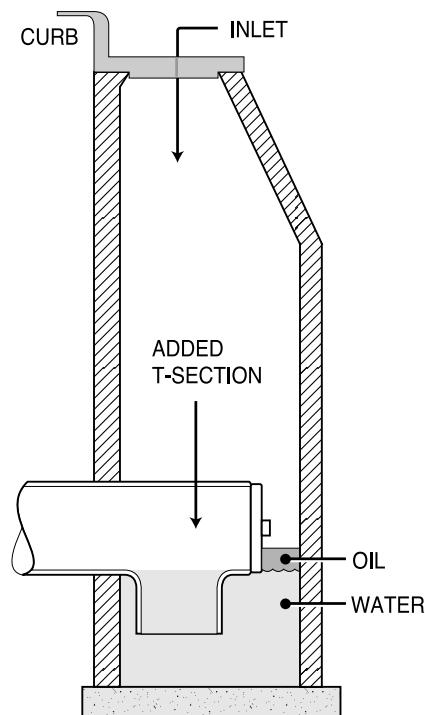

## Maintaining Your Oil/Water Separator

Oil/water separators can't function properly unless they're regularly maintained. To ensure that separators are properly maintained, it's a good idea to hire a professional service. (Don't use a septic tank cleaning service; there's no legal, environmentally safe way for them to dispose of oily wastes.) No matter who performs your maintenance, make sure that wastes are taken to a licensed treatment facility, where the oil will be further separated for recycling.

If you choose to perform your own maintenance, follow these general guidelines:

**Simple oil/water separators:** Clean simple separators immediately after every spill. For routine maintenance,

clean them as you would a regular catch basin (when deposits fill half of the area between the bottom of the catch basin and the bottom of the pipe).

**API oil/water separators:** Regularly clean each chamber. Failure to do so will cause previously trapped pollutants to be resuspended and discharged.

To determine an appropriate cleaning schedule, inspect separators after several rain events and note the amount of collected residue. At the very least, separators should be cleaned twice a year. Continue to inspect separators on a regular basis to ensure that cleaning schedules are adequate.

Replace dirty standing water with clean water to prevent oil from being washed out of the separator. Since it could be explosive, standing water that's been removed must be handled as a hazardous waste.

If your separator has oil absorbent pads, replace them in the spring, in the fall, and additionally, if needed. If your separator doesn't have oil absorbent pads, consider putting them in. By maintaining the pads you can reduce or eliminate the need to clean out the entire oil/water separator.

For more information about installing and maintaining oil/water separators, contact one of the agencies listed under "Getting Help."

### GETTING HELP

Community Partners for  
Clean Streams Program..... (313) 994-8344

Washtenaw County Drain  
Commissioner's Office ..... (313) 994-2525

**Utilities Departments:**

City of Ann Arbor ..... (313) 994-2466  
City of Ypsilanti ..... (313) 482-1025

Michigan Department of  
Environmental Quality ..... (800) 662-9278



# Maintaining Stormwater Management Systems



## Why be concerned?

The importance of maintaining stormwater management systems can't be overemphasized. No matter how well designed, without regular maintenance drainage systems will eventually stop functioning properly, losing their ability both to control flooding and to remove pollutants from stormwater.



## Maintaining Your Detention System

Retention ponds are designed to store stormwater runoff without releasing it (except through evaporation, soil infiltration, or emergency bypass). Detention ponds are designed to store stormwater runoff and release it at a controlled rate to systems that ultimately lead to rivers and streams. In order to function properly, retention and detention systems must be rigorously maintained. Your system may have special maintenance requirements; however, in general:

- Maintain thick, native vegetation around ponds to slow and filter stormwater before it enters them. Avoid mown lawn to the water's edge.
- Regularly remove accumulated sediment and debris, especially around outflow control devices.
- Regularly check and clean inlet sedimentation basins to ensure that there's enough storage volume for them to function properly.
- Inspect the entire system at least once a year. If possible, inspections should be carried out by a licensed engineer.
- Immediately repair or replace any damaged or defective structural components.

## Herbicide-Free Algae Control

Herbicides and algicides used to control plant growth in ponds can pollute both retention ponds and waters downstream. Algae and aquatic plants can be controlled by limiting the input of nutrients (such as fertilizers, leaves and lawn clippings) and providing aeration.

## Developing and Implementing a Maintenance Plan

A plan will help to expedite proper maintenance. Plans will vary, depending on the business and site; however every plan should contain the following:

1. A delineation of all stormwater management facilities (including maintenance access and vegetated buffer areas).
2. Provision for the routine and non-routine inspection of every component within the system. A licensed engineer should be retained to inspect structural facilities and to conduct emergency inspections.
3. A list of the tasks required to maintain each component of the stormwater management system and a schedule for completing these tasks. This should include both preventative and corrective activities.
4. The party responsible for performing each of the maintenance activities described.
5. A description of on-going landscape maintenance needs, including soil erosion control.

For help determining how to maintain your system, call one of the agencies listed under "Getting Help."

## GETTING HELP

- Community Partners for Clean Streams ..... (313) 994-8344
- Michigan Department of Environmental Quality ..... (800) 662-9278
- In the City of Ann Arbor:*  
Utilities Department ..... (313) 994-2466





**Community Partners for Clean Streams  
WATER QUALITY ACTION PLAN**

---

**SERIES #2: MAINTAINING ENGINEERED STORMWATER CONTROLS  
Fact Sheets 2.1,2.2 and 2.3**

**Completing Your Water Quality Assessment and Action Plan**

To create your own "Water Quality Action Plan", please fill out the following checklist (instructions are included on the other side of this page). The "Actions" in this checklist directly correspond to recommendations made within this handbook. If you have any questions or would like help completing this form, please contact the Community Partners for Clean Streams Program Manager at (313)994-8344 or (313)994-2525. Send completed checklists to:

Community Partners for Clean Streams  
Washtenaw County Drain Commissioner's Office  
110 N. Fourth Ave.  
Ann Arbor, MI. 48107-8645  
Fax: (313)994-2459

*NOTE: To become a "Community Partner for Clean Streams", all checklists that apply to your business must be filled out and returned. A complete listing of all program handbooks/checklists is provided on the inside of the back cover. To obtain copies, contact the Community Partners Program Manager.*

**Business Information**

**Business Name:** \_\_\_\_\_

**Type of Business:** \_\_\_\_\_ **No. of Employees:** \_\_\_\_\_

**Address:** \_\_\_\_\_ **Zip:** \_\_\_\_\_

**Contact Person:** \_\_\_\_\_ **Title:** \_\_\_\_\_ **Phone:** \_\_\_\_\_

**Water Quality Action Plan prepared by:** \_\_\_\_\_ **Date:** \_\_\_\_\_

**Business Activities That Can Affect Water Quality**

Please check the activities that your business is responsible for:

- |   |  |  |
|---|--|--|
| <input type="checkbox"/> Storing materials              | <input type="checkbox"/> Maintaining buildings/pavement              | <input type="checkbox"/> Maintaining landscapes          |
| <input type="checkbox"/> Spill containment and response | <input type="checkbox"/> Maintaining constructed stormwater controls | <input type="checkbox"/> Site design and/or construction |
| <input type="checkbox"/> Managing wastes                | <input type="checkbox"/> Managing employees                          |  |



**Directions for Completing this Checklist (see sample below):**

1. For each action, check the appropriate box in the ASSESSMENT column (*Not Applicable, Always, or Needs Improvement*).
2. Next, check the corresponding box in the ACTION PLAN column (*Plan to Continue or Plan to Improve*).
3. For every current *and* proposed action, indicate who will do it and in when.
4. If possible, provide additional information (about both current *and* proposed activities) in the space preceded by the word "Action(s)". If insufficient space has been provided, please feel free to attach extra pages.
5. If the action requires ongoing employee training or commitment from management, check that box as a reminder to include it in your employee education activities.
6. Detach the checklist from this handbook and return it to Community Partners for Clean Streams!

EXAMPLE	ASSESSMENT	ACTION PLAN
<p>1. Steps are taken to minimize the amount of potentially polluting materials and wastes kept in storage.</p>	<p><input type="checkbox"/> Not applicable  <input type="checkbox"/> Always  <input checked="" type="checkbox"/> Needs improvement</p>	<p><input type="checkbox"/> Plan to continue  <input checked="" type="checkbox"/> Plan to improve</p>
<p><b>Who:</b> <u>Purchasing Dept./Facilities Manager</u></p>		
<p><b>Schedule:</b> <u>As applicable</u></p>		
<p><b>Action(s):</b> <u>Deicing chemicals will be purchased in smaller quantities and stored in water-proof, leak-proof containers</u></p>		
<p><input type="checkbox"/> Requires ongoing education/commitment</p>		

**SERIES #2: MAINTAINING ENGINEERED STORMWATER CONTROLS**  
**(Fact Sheets 2.1, 2.2 and 2.3)**

**ASSESSMENT**

**ACTION PLAN**

**1. Leaves and other debris are regularly removed from storm drain grates.**

- Not applicable  
 Always       Plan to continue  
 Needs improvement       Plan to improve

**Who:** \_\_\_\_\_

**Schedule:** \_\_\_\_\_

**Action(s):** \_\_\_\_\_

\_\_\_\_\_

Requires ongoing education/commitment

**2. Catch basins are regularly maintained and wastes are disposed of properly.**

- Not applicable  
 Always       Plan to continue  
 Needs improvement       Plan to improve

**Who:** \_\_\_\_\_

**Schedule:** \_\_\_\_\_

**Action(s):** \_\_\_\_\_

\_\_\_\_\_

Requires ongoing education/commitment

**3. Oil/water separators are installed in all high-traffic areas.**

- Not applicable  
 Always       Plan to continue  
 Needs improvement       Plan to improve

**Who:** \_\_\_\_\_

**Schedule:** \_\_\_\_\_

**Action(s):** \_\_\_\_\_

\_\_\_\_\_

Requires ongoing education/commitment

**4. Oil/water separators are regularly maintained and wastes are disposed of properly.**

- Not applicable  
 Always       Plan to continue  
 Needs improvement       Plan to improve

**Who:** \_\_\_\_\_

**Schedule:** \_\_\_\_\_

**Action(s):** \_\_\_\_\_

\_\_\_\_\_

Requires ongoing education/commitment



**5. Detention and retention systems are regularly inspected and maintained.**

- Not applicable
- Always  Plan to continue
- Needs improvement  Plan to improve

**Who:** \_\_\_\_\_

**Schedule:** \_\_\_\_\_

**Action(s):** \_\_\_\_\_

\_\_\_\_\_

- Requires ongoing education/commitment

---

**Additional Comments:**

# COMMUNITY PARTNERS FOR CLEAN STREAMS FACT SHEETS

## **FACT SHEET:           STORMWATER RUNOFF AND WATER QUALITY**

### **SERIES #1:           HOUSEKEEPING PRACTICES**

Fact Sheet 1.1: Storing Materials and Wastes  
Fact Sheet 1.2: Preventing and Cleaning Up Spills

### **SERIES #2:           MAINTAINING ENGINEERED STORMWATER CONTROLS**

Fact Sheet 2.1: Catch Basin Care  
Fact Sheet 2.2: Oil/Water Separators  
Fact Sheet 2.3: Maintaining Stormwater Management Systems

### **SERIES #3:           MAINTAINING EQUIPMENT AND VEHICLES**

Fact Sheet 3.1: Storing and Maintaining Equipment and Vehicles  
Fact Sheet 3.2: Washing Equipment and Vehicles

### **SERIES #4:           MAINTAINING BUILDINGS AND PAVEMENT**

Fact Sheet 4.1: Outdoor Pressure Washing  
Fact Sheet 4.2: Maintaining Building Facades  
Fact Sheet 4.3: Maintaining Paved Areas  
Fact Sheet 4.4: Using and Storing Deicing Materials  
Fact Sheet 4.5: Cooling Water Systems

### **SERIES #5:           MAINTAINING LANDSCAPES**

Fact Sheet 5.1: Maintaining Healthy Lawns, Shrubs and Trees  
Fact Sheet 5.2: Using Fertilizer  
Fact Sheet 5.3: Integrated Pest Management  
Fact Sheet 5.4: Using Pesticides

### **SERIES #6:           SITE DESIGN AND CONSTRUCTION**

Fact Sheet 6.1: Designing Landscapes for Water Quality  
Fact Sheet 6.2: Designing Stormwater Management Systems  
Fact Sheet 6.3: Clearing and Grading Land

### **SERIES #7:           MANAGING WASTES**

Fact Sheet 7.1: Minimizing Waste  
Fact Sheet 7.2: Recycling  
Fact Sheet 7.3: Waste Disposal

### **SERIES #8:           EDUCATION**

Fact Sheet 8.1: Education and Community Leadership

*This program has been partially funded by a grant from the U.S. Environmental Protection Agency under Section 319 of the Clean Water Act. The reproduction of written materials is encouraged, with appropriate citation.*

