



GREEK REVIVAL ARCHITECTURE

North Driving Tour of 19th Century Greek Revival Structures Washtenaw County, Michigan

AMERICA'S FIRST NATIONAL ARCHITECTURAL STYLE

The Greek Revival style is recognized as America's first national architectural style. Popular between 1825-1860, this style was embraced by a nation driven by fervor for independence at the end of the War of 1812, when the British finally left American soil. Settlers strongly identified with the Greek ideals of democracy. During the early decades of the 19th century, they used Greek names for their new towns and villages, such as Utica, Athens, Ypsilanti, and Syracuse. The Greek Temple became a symbol of independence and American builders adapted elements of the style to the simple houses constructed in this new land.

The Greek Revival architectural style was adopted in Washtenaw County from the beginning of settlement in the 1820s until the end of the Civil War in 1865. The style is found primarily in houses, but is also found in churches, school houses, inns, mills, and other commercial buildings.

Characteristics of this style include rectangular buildings with a medium to low-pitched gable roof and often covered with clapboard. Typical Greek Revival buildings may also be constructed of brick, cobblestone, or adobe. Elements of this style include a full or broken triangular pediment at the gable ends, a frieze board, corner boards or pilasters, round or square columns, six-over-six double-hung rectangular windows, and elegant door surrounds. For more architectural terms, see the glossary on page 2.

GREEK ARCHITECTURAL ELEMENTS

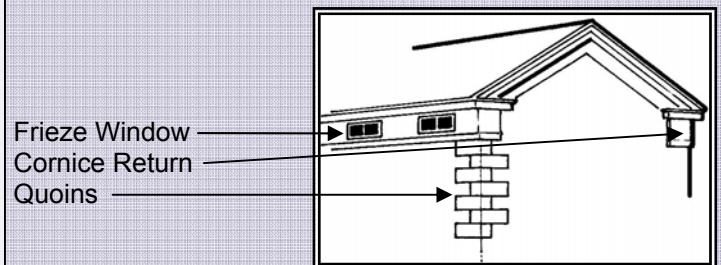
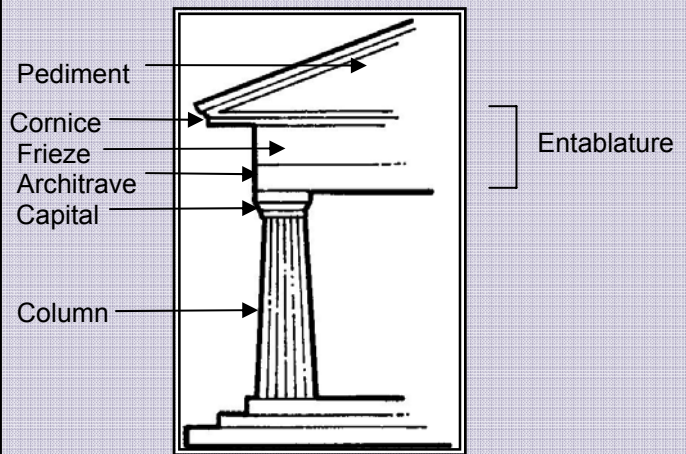

RESPECT, PLEASE!

The historic resources depicted herein are **private property** and are not open to the public. Please respect the owners' privacy and do not trespass.

The tour is intended to be enjoyed from the public right-of-way only.



GREEK REVIVAL ARCHITECTURE GLOSSARY

Adobe: *hardened mud blocks used for wall construction, often covered with stucco*

Architrave: *the lower most of the three parts comprising the entablature: architrave, frieze, and cornice*

Capitals: *the simple or decorative top portion of a column*

Corinthian Order: *one of the most decorated of the recognized orders of Greek architecture*

Cornice: *the uppermost part of the entablature in Greek architecture, it projects outward and is often decorated*

Cornice Returns: *a pair of cornices that wraps around the corner of a gable end without meeting; giving the impression of a pediment*

Doric Order: *one of the least decorated of the six generally recognized orders of Greek and Roman architecture*

Entablature: *the entire horizontal structural member supported by columns; composed of the (lowest to highest) architrave, frieze, and the cornice*

Frieze: *the middle portion of the entablature*

Frieze Windows: *small windows located within the frieze*

Ionic Order: *a moderately decorated order of the six generally recognized orders of Greek and Roman architecture; easily recognized by its capitals with "swirls"*

Pediment: *the triangular shaped front piece found on Greek temples*

Pilaster: *a faux column that is engaged in the wall for decoration rather than support of a beam or lintel; often found at corners and doors*

Quoins: *alternating rectangles of stone or brick used at the corners of a building for corner support and stability*

Stucco: *a plaster-like material made of lime, sand, and water; often spread over adobe brick or other masonry*

DID YOU KNOW?

Settlers reused and recycled their buildings or building parts. An example is found at 4560 South Wagner Road, where a Greek Revival structure northwest of the farmhouse is now used as an out-building.

Photo © Fred Golden



Sharon Mills County Park

*Open to the Public
Not Pictured on Map*

5701 Sharon Hollow Road

Sharon Mills was one of the sites purchased by Henry Ford for his village industries initiative during the 1920s and 1930s. Cigar lighters were manufactured at this site until the mid-1940s when the initiative proved no longer viable. The mill was later a private residence and a winery. The site was purchased by the Washtenaw County Parks and Recreation Commission in 1999, and rehabilitated in 2002.

For tour information, directions, and hours,
call 734.222.9098 or visit:

http://www.ewashtenaw.org/government/departments/parks_recreation/sharonmills/pr_pksharon.html

19TH CENTURY ARCHITECTURE

GREEK REVIVAL ARCHITECTURE FORMS

The structures that have a large front gable with columns and a pediment, are known as **temple front** Greek Revivals, which resemble true Greek Temples. The form called "**hen and chicks**," or basilica, is unique to Southeast Michigan. The "hen" is a front gable two story central core resembling a temple front, and the "chicks" are one story side wings.

Many early Michigan settlers originated from New England and New York State. They brought with them the New England one-and-a-half **side gable** form, with frieze windows to let in light and air to the upper floor. Houses that reflect the **upright and wing** form usually consist of a two story upright and a one-and-a-half story wing.

GREEK REVIVAL ARCHITECTURE MATERIALS

Early in the 19th century, builders used materials that were available. Logs were used to quickly construct rough dwellings. Trees were still abundant in the 1820s and 1830s when sawn lumber was more readily available, which is why many Greek Revival structures were built of **wood**. **Cobblestone** was also obtainable and proved to be a fine construction material. Later, **brick** houses were also considered desirable for greater durability and fire safety.

The most unusual material used for Greek Revival architecture found in Washtenaw County is **adobe brick**: hardened mud blocks covered with **stucco**. A number of these adobe brick houses are attributed to Stephen Mills, a brick builder from New Jersey. He came to Washtenaw County in 1833, and is known to have built houses of brick, cobblestone, and adobe brick.

SITE 1. Gray Farmhouse
8540 Island Lake Road, Dexter Township

Built in 1834 by Judge Samuel Dexter for local physician Amos Gray, this house is an outstanding example of an *upright and double wing* form. It features massive square columns that frame porches on two stories and the full triangular pediment above.



SITE 2. Gordon Hall ●
8341 Island Lake Road, Webster and Scio Townships



A classic *temple front*, **Gordon Hall** is one of the most well-known Greek Revival structures in Washtenaw County. It has a five bay façade with massive columns and a full pediment. Built between 1841 and 1843 by Judge Samuel Dexter, the structure was named for his

mother's family. Dexter established the village of Dexter in 1824, naming it in honor of his father. Dexter's granddaughter later passed the estate on to the University of Michigan. The Dexter Area Historical Society and Museum purchased the property for use as a museum.

ALONG THE WAY... ▲

In the **Village of Dexter**, drive down Central Avenue to enjoy several good examples of the Greek Revival style. Across the street from the Dexter Mill, at 3512 Central, is a *hen and chicks* Greek Revival known as the Litchfield House. This site is listed in the National Register of Historic Places.

For more information on Dexter area history, visit:

<http://www.hvcn.org/info/dextermuseum>

SITE 3. John Stanton House
6015 Mast Road, Webster Township

This farmhouse is in a familiar form called the *upright and wing*. Typical features include the frieze windows on the wing section and the hip roof over the porch. *Cornice returns* are present on the front and side gables. The house was built around 1860 by the widow and son of John Stanton, a farmer, several years after his death.



SITE 4. Williams-Mast House
4580 Farrell Road, Webster Township



The **Williams-Mast House** is a unique form of Greek Revival architecture with a hipped roof and *square* shape. It has square columns, frieze windows, and a recessed porch. The house was built in 1828 by John Williams.

SITE 5. Webster United Church of Christ ◻
5484 Webster Church Road, Webster Township

The *front gabled* **Webster United Church of Christ**, for which the road is named, was built in 1834 by Henry V. Libhart. Its square tower and Italianate detailing above the windows were added in the late 19th century.



SITE 6. The Tubbs Farmhouse
3735 Tubbs Road, Scio Township



On the west side of the road, the **Tubbs Farmhouse** is a clapboard *hen and chicks* house with a fieldstone foundation. Note the trim work and cornice returns on the front gabled section and the strong triangular lines of the "chickwings." The house

was built by George Tubbs, who came to Washtenaw County from Ontario County, New York. It was built sometime before 1856.

SITE 7. Reeves House
2886 W. Joy Road, Webster Township

The **Philip Reeves House** is an example of an *upright and wing* form, although the upright portion is wider than those found on most Greek Revivals, and is one-and-a-half stories, rather than two stories tall. The house is composed of fieldstone, with quoins made of larger boulders. Local tradition holds that the original log cabin on the property was the wing portion and that it was covered with stone when the rest of the house was built around the middle of the 19th century.



KEY TO LISTS & DESIGNATIONS

- State Register of Historic Places
- ▲ National Register of Historic Places
- Washtenaw County Historic District



SITE 8. Boyden Farm
3300 Joy Road, Webster Township



The **Luther Boyden Farm** is an exceptional example of an intact historic farmstead with architecturally significant buildings. The house was constructed c.1860, and is a brick four-bay front gabled structure with Italianate features, including brackets and porch

detailing. Another outstanding building on the property is the brick Italianate carriage house located east of the main house. Luther Boyden arrived in Washtenaw County from Massachusetts in 1826. He was influential in animal breeding practices as well as educational and religious matters. His barn served as the site for religious services before the Webster Church was built.

SITES OF NOTE

Highlighted Individually on Tour Map

Leland House
3850 E. North Territorial Road, Northfield Township

Located west of Earhart Road, this house is unusual for its wide *front gable* form that may have evolved from a *hen and chicks* arrangement. Details include thick pilasters, robust square columns on the porch, and fine detailing around the window in the front gable.



Douglass-Nanry House
6595 Plymouth Road, Superior Township



This house is a wonderful example of the *hen and chicks* or *basilica* arrangement unique to southeast Michigan. The bones of the classical details are clearly evident in the recessed porch, square columns, and generous entablatures.

It was built c.1860 for Aaron Douglass, a prosperous farmer who sold his farm and furnishings to John Nanry in 1864. The Nanry family maintained the estate until after 1940.

Burnett House
3555 West Delhi Road, Scio Township

This residence is an excellent example of a cobblestone *hen and chicks* Greek Revival. Features include stone quoins and heavy cornice returns.



ADDITIONAL SITES OF NOTE

Highlighted Individually on Tour Map

Ezra Lay House
3401 Berry Road, Superior Township

Moved in 1966 to its present location, the **Ezra Lay House** belonged to the first known nurseryman of the Northwest Territory. Ezra Lay and his brother Zina came from New York to Michigan in 1832, and settled along Michigan Avenue east of Ypsilanti.



They moved approximately 25,000 fruit trees, shrubs and seedlings to the farm. The house was built in 1833 and is said to have had a colorful history, including periods as a tavern, a blind pig, and an apartment building during WWII. In 1966 when it was scheduled for demolition, Mr. and Mrs. Charles Hagler moved the dwelling to its present site. A new foundation was dug and the house was carefully rehabilitated. A classical style garage and portico were added to complement the house. Mr. and Mrs. Brad Perkins, owners of the property in the 1990s, donated a large portion of the land to the Southeast Michigan Land Conservancy to protect the rural character of the area.

Dixboro Church ▲
5221 Church Street, Dixboro, Superior Township



The **Dixboro United Church of Christ**, located at the north end of Short Street at Church Street, is undergoing a rehabilitation and restoration project at the time of this publication. The restoration will include a replica of the original steeple. The church was built in 1858 as a Methodist

Episcopal Church. It is a classic *front gabled* structure with a full pediment and large pilasters dividing the sections of the façade, as well as corner pilasters.

Treadwell-Popkins House
4004 Ave Maria Drive (Old Earhart Road), Ann Arbor Township

Located at the north end of Old Earhart Road, this brick house is a five-bay *side gabled* New England one-and-a-half Greek Revival. It features frieze windows with detailed trim, cornice returns, and a porch with typical Greek Revival elements. The house was built c.1860 and was at one time part of a prosperous farm. Presently it is the rectory for Christ the King Catholic Church.





GREEK REVIVAL ARCHITECTURE

South Driving Tour of 19th Century Greek Revival Structures Washtenaw County, Michigan

SITE 1. Orrin White House 2940 Fuller Road, Ann Arbor ▲

Local farmer and civic leader Orrin White built this *cobblestone* house c.1840 with his wife Ann. According to the National Register Nomination, it was built in several stages. The front elevation of the house, known as the *façade*, features a herringbone pattern of stones, while the east elevation has randomly placed stones. Other details on the house include stone corner quoins and detailed wood trusswork in the gable end.



SITE 2. Ticknor-Campbell House 2781 Packard Road, Ann Arbor ▲ ■

Open to the Public



The **Ticknor-Campbell House**, otherwise known as **Cobblestone Farm**, is listed in the National Register of Historic Places and the State Register of Historic Sites. This unique house is composed of stone in a coursed herringbone pattern on the *façade* similar to the Orrin White House. It was

built in 1844 by Benajah Ticknor, a U.S. naval surgeon from Connecticut. His brother Heman, a politician, also lived on site and managed the farm. The Campbell family purchased the property in 1881 and continued farming for 91 years. The site was purchased by the City of Ann Arbor in 1972 for use as a farm life museum interpreted to the mid-19th century.

For hours of operation and tour information call 734-994-2928 or visit

http://www.ci.ann-arbor.mi.us/CommunityServices/Parks/Cobblestone/cobblestone_main.html

ALONG THE WAY... ▲

In the **City of Saline**, drive down Michigan Avenue, also known as the US-12 Heritage Trail. This route links Detroit to Chicago. It was the second road in the nation built by the federal government, after the construction of the National Road. Several good examples of 19th century architecture remain along this segment, many of which are listed in the National Register of Historic Places.

For more information on Saline area history, visit:

<http://salinehistory.org>

SITE 3. Cody Farm 670 Textile Road, Pittsfield Township

A significant resource, the **Cody Farm** was designated as a Michigan Centennial Farm in 1989. It is located on a tract purchased by the Cody family in 1836. The *wood* Greek Revival house is a side gabled structure with a highly detailed Italianate porch. The house and farm buildings remain largely unchanged. The owners were relatives of Buffalo Bill Cody, and tradition holds that he stayed at the farm when his Wild West exhibition passed through the area.



SITE 4. Sutherland-Wilson Farm 797 Textile Road, Pittsfield Township



The **Sutherland-Wilson Farm** is now surrounded by development, but was farmed by the same family for over 150 years. The property was purchased by Langford Sutherland in 1832. The house is a fine example of the New England one-and-a-half cottage

with a central hall and a combination of both Doric and square columns on the front porch. The farm is currently being restored by the Pittsfield Township Historic Society. For more information call 734-971-2384 or visit www.pittsfieldhistory.org.

SITE 5. Hurd-Tefft House 1880 Textile Road, Pittsfield Township

This side gabled one-and-a-half story house was reportedly built by Stephen Mills in c.1850, for Arba Hurd of Dutchess County, NY. It was owned in the early 20th century by the Tefft family. The house is constructed of *adobe brick* with a *stucco* finish, both materials unusual to the Midwest. After the exterior was coated with stucco, the builder scored it to resemble stone block. This is one of several Washtenaw County houses of this type; most are attributed to Mills.



SITE 6. Lohr House
4456 Lohr Road



This upright and double wing *brick* house was the anchor of a prosperous farmstead with as many as fourteen outbuildings at its peak the early 20th century. The house was constructed c.1866, reportedly by local builder Stephen

Mills, during a time when the Greek Revival period was phasing into the Italianate period. Elements of both styles are found on the house. Greek Revival details include the pediment on the upright portion and the square columns. Italianate influence can be seen in the deep eaves and many brackets on the house.

SITE 7. McCollum-Schmitt House
4576 Ann Arbor-Saline Road

Like many others in the area, this house is also attributed to local builder Stephen Mills. It is consistent with his characteristic materials of *stucco* exterior over *adobe brick*. Built in c.1850, it is a one-and-a-half story New England cottage.



Greek Revival elements include the decorated grills at the frieze, cornice returns, and square columns on the porch. The Schmitt family bought the property in 1890 and it remained in that family for many years.

SITE 8. Knight House
4944 Scio Church Road



This house is a coursed *cobblestone* one-and-a-half story New England cottage. It sits on a bank on the north side of the road, almost out of view. It has stone quoins, heavy cornice returns, and frieze windows which are larger than usual for this style. The Knight

family owned the property as early as 1856. A schoolhouse was built to the east, called the Knight School.

SITE 9. Pope House
1251 S. Zeeb Road

A large scale example of Greek Revival architecture, the Pope House is an upright and wing *brick* house with a thick frieze board, frieze windows on the wing, and cornice returns. The steep roof, form, and massing of this house indicate that it is a



later example of the Greek Revival style, at a time when architectural taste was transitioning toward the Italianate style.

SITES OF NOTE

Highlighted Individually on Tour Map

Newton-Sheldon House
6871 Saline Waterworks Road



This side gabled stucco house is also attributed to Stephen Mills. It has a stucco exterior, decorative grills in the frieze, and thick square columns on the hipped-roof porch.

Weller's Carriage House
555 W. Michigan Avenue, Saline

Open to the Public

Located just west of downtown Saline at the river, this historic mill was purchased by Henry Ford in the 1920s for use in his Village Industries initiative, connecting farmers more closely with the manufacturing process. He used the facility for processing soybeans for use in plastics and paint for automobiles. He also moved a schoolhouse from Macon to a location across the street (600 W. Michigan Avenue) for the benefit of the children of his employees at the small processing plant.



Weller's is open periodically for tours and events.
For information, call 734.429.1115 or visit
<http://www.wellersweddings.com/>

Brinkerhoff-Burg House
9180 Saline Milan Road



Located south of Saline, this site has the consistent appearance of a Stephen Mills house, with a stucco finish covering adobe brick construction. It was built c.1845 for H.H. Brinkerhoff, the original land owner. The property later sold to John Burg in 1874, and remained in that family until 1983.



GREEK REVIVAL ARCHITECTURE

City Highlights Washtenaw County, Michigan *Not depicted on maps*

Kempf House 312 S. Division, Ann Arbor



Open to the Public

The Bennett-Kempf House was built in 1853, and is a temple front Greek Revival with a full pediment, ornate grillwork in the frieze, and substantial square columns. Now a museum, the house tells the story of prominent local musicians Reuben and Pauline Kempf during the late 19th and early 20th centuries. An 1877 Steinway concert grand piano is one of the many prized artifacts on display.

For museum hours and events, call 734-994-4898 or go to www.kempfhousmuseum.org



Ladies Literary Society 218 N. Washington, Ypsilanti



The Ladies Literary Society house is a temple front Greek Revival with three bays, square columns, and decorated frieze grills. In addition, notice the dentils under the frieze windows and the detailing along the pediment cornice. The

columns are paneled at the corners, suggesting fluting. Arden Ballard built this house for William Davis around 1842. Located within the Ypsilanti Local Historic District, the Ladies Literary Society bought the property in 1913 and still own and operate it today.

Wilson-Wahr House 126 N. Division, Ann Arbor



One of the most famous residences in Ann Arbor, this house was built in 1843 by Judge Robert S. Wilson. In 1892, it was purchased at auction by publisher George Wahr. He leased the house for twenty years, and later occupied it with his wife, Emma. The house remained in the Wahr

family until 2002, when two local preservationists bought the property for restoration.

Anderson House 2301 Packard, Ann Arbor



John Anderson purchased land in Pittsfield Township in 1831, and his son William built this temple front Greek Revival, which stayed in the family for over a century. The house has three



bays, the four columns, grills in the frieze openings, and board and batten siding. Dr. Inez Wisdom, a prominent local physician, bought the property in 1937 and added a small chapel to the south side of the house. In 1953 she gave the chapel and grounds to the Episcopal Diocese of Michigan and the St. Clare of Assisi Parish was established. The church building was constructed by the parish in 1968.

Ballard-Breakey House 125 N. Huron, Ypsilanti



Originally a modest house of brick and stone, the Ballard-Breakey House was constructed around 1830 by Arden H. Ballard, who was active locally and served as the village president. The massive columns



were added in the 1840s. The house derives the second portion of its name from Dr. Breakey, a judge who lived in the house during the 1960s. Additions have been built and function as condos, but the three-bay temple front remains a prominent resource in the Ypsilanti Local Historic District.

Towner House 303 N. Huron, Ypsilanti



The Towner House, owned by the First Presbyterian Society, is believed to be the oldest house remaining on its original foundation in Ypsilanti. It was built in 1837 and was later owned by the Towner family for 100 years. The

house is unusual for its wide front gable. Note the decorated columns on the porch, likely added later. The house is situated in the Ypsilanti Local Historic District.

Washtenaw County, Michigan Heritage Driving Tours

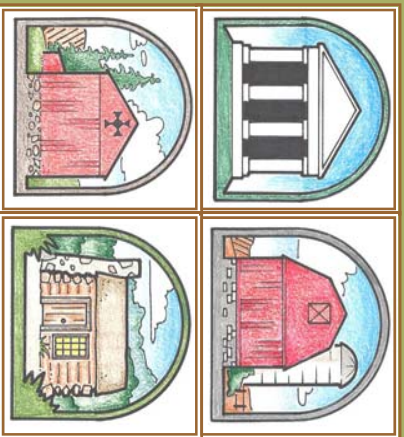

Tour 1:
ESEEK PRAY TRAIL
Learn about early Washtenaw County settlers.

Tour 2:
GREEK REVIVAL ARCHITECTURE:
NORTH & SOUTH TOURS
Enjoy an elegant architectural style.

Tour 3:
HISTORIC BARNNS
Discover more than just red barns.

Tour 4:
GERMAN HERITAGE
See beautiful farming landscapes.

For more information
and printable tour brochures, visit
<http://preservation.ewashtenaw.org/>

THANK YOU
TO OUR SPONSORS & PARTNERS

Michigan Department of History,
Arts and Libraries
Ann Arbor Area Convention & Visitors Bureau
Saline Area Chamber of Commerce
Saline Area Historical Society
Washtenaw County Historical Consortium
Ypsilanti Area Convention & Visitors Bureau



© 2007 Washtenaw County Government
Heritage Tourism Map Project
Department of Planning & Environment
Historic Preservation Program
705 North Zeeb Road
Ann Arbor, Michigan 48107

<http://preservation.ewashtenaw.org/>



Produced by Ina Hanel-Gerdenich, Kathy Holtz,
Anne Keykes and Melissa Wilton-Pung.
Graphic assistance by
Anthony Bedogne and Thomas Winebrenner.

FUNDING AND DISCLAIMER STATEMENT

This publication has been financed in part with federal funds from the National Park Service, U.S. Department of the Interior. The Washtenaw County Department of Planning & Environment receives federal financial assistance for identification and protection of historic properties.

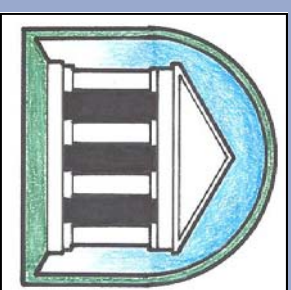

GREEK
REVIVAL
ARCHITECTURE

TOUR 2

A

Washtenaw County,
Michigan
Heritage Driving
Tour







Ballard-Breakey House, 125 N. Huron, Ypsilanti



GREEK REVIVAL ARCHITECTURE

North Driving Tour of 19th Century Greek Revival Structures Washtenaw County, Michigan

LEGEND

-  Upright & Wing or Double Wing
-  Front Gable
-  Square
-  Hen and Chicks
-  Side Gable

Sites:

- 1 Gray Farm
8540 Island Lake Rd
- 2 Gordon Hall
8341 Island Lake Road
- 3 John Stanton House
6015 Mast Road
- 4 Williams-Mast House
4580 Farrell Road

- 5 Webster Church
5484 Webster Church
- 6 Tubbs House
3735 Tubbs Road
- 7 Philip Reeves House
2886 W. Joy Road
- 8 Boyden Farm
3300 W. Joy Road

Additional Sites:
Burnett House
 3355 W. Delhi

- Leland House**
 3850 E. North Territorial
- Douglas-Narry House**
 6595 Plymouth Road
- Ezra Lay House**
 3401 Berry Road
- Dixboro Methodist Church**
 5221 Church Street
- Treadwell-Popkins House**
 4004 Ave Maria Drive

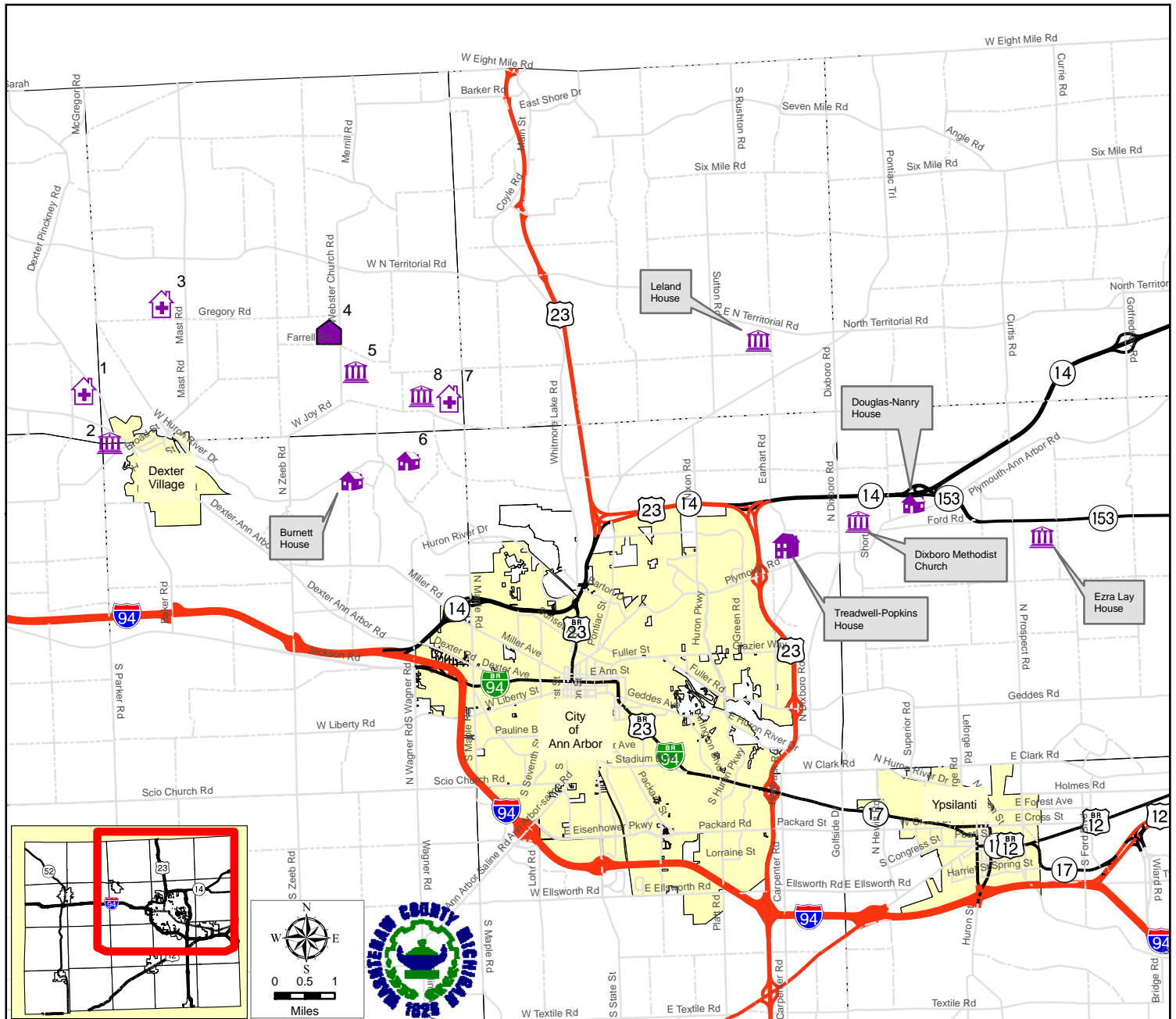







GREEK REVIVAL ARCHITECTURE

South Driving Tour of 19th Century Greek Revival Structures Washtenaw County, Michigan

LEGEND

-  Cobblestone
-  Brick
-  Wood
-  Stucco

Sites:

- | | | | | | |
|---|---|---|--|--|---------------------------------|
| 1 | Orrin White House 2940 Fuller Road | 5 | Hurd-Tefft House 1880 Textile Road | 9 | Pope House 1251 S. Zeeb Road |
| 2 | Ticknor-Campbell House 2781 Packard Road | 6 | Lohr House 4456 Lohr Road | Additional Sites: | |
| 3 | Cody Farm 670 Textile Road | 7 | McCollum-Schmitt House 4576 Ann Arbor-Saline Road | Newton-Sheldon House 6871 Saline-Waterworks | |
| 4 | Sutherland-Wilson Farm 797 Textile Road | 8 | Knight House 4944 Scio Church Road | Weller's Carriage House 555 W. Michigan Avenue | |
| | | | | Brinkerhoff-Burg House 9180 Saline-Milan Road | |

